

**Gas Booster Pressure Test Unit (GTU)**

**Technical Data Sheet**

**Order Code: GTU-DLE15-1-GG**

**Features**

- Maximator Air driven Gas Booster Model **DLE15-1-GG**
- Air Drive Regulator / Pressure Gauge / Speed control valve
- Inlet Pressure Gauge 100mm Glycerine filled
- Outlet Pressure Gauge 100mm Glycerine filled
- High Pressure Outlet Isolation Valve
- Manual Pressure Release valve
- Robust Stainless Steel frame for ease of transportation and Protection

**Technical Data / System Scope**

Max Outlet Pressure:	150 bar / 2175 psi	
Air drive pressure:	1-10 bar / 14,5–145 psi	
Pressure ratio:	1:15	
Compression ratio :	1:20	
Displacement volume/stroke	122 cm3	
Max Cycles	130 / min	
Stall Pressure	PB = i * pL + pA	
Connections	Inlet:	1/4" BSP
	Outlet:	1/4" BSP
	Air :	3/4" BSP
Air Pressure Gauge	0-11bar / 160psi	
Pressure Gauge	0-1724bar / 25000psi 100mm glycerine filled	
Max Temp	100°C	

**Construction**

Frame	Stainless Steel	
Compressor Head	1.4305	
HP Cylinder	1.4542	
Piston	1.4305 (hardened)	
Valves Fittings & Tubing	316 ss	
Seal package:	Inert Gas :	PTFE, Viton
	Oxygen :	PTFE, Viton
	CO2 :	PTFE, NBR
Overall	900w x 500h x 500d mm	
Nett Weight	41kg	

**Options**

- Inlet / Outlet Hoses
- Outlet Pressure regulator
- Chart Recorder connection Point
- NPT connections

**Performance**

IF IN DOUBT, ASK!!

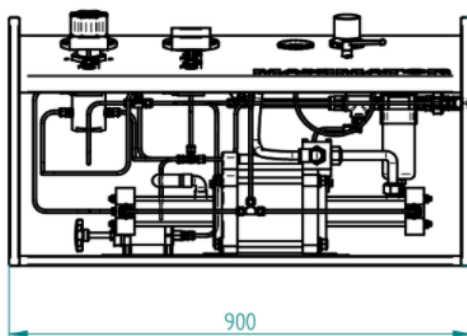
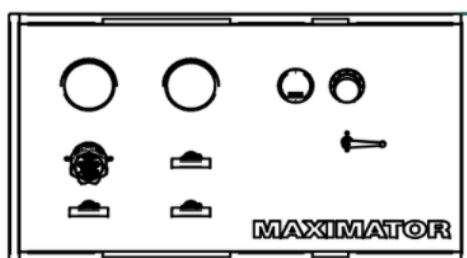

GAS VENT  
GAS OUTLET  
GAS INLET

